

THE ROSE COLLECTION OF MOCCASINS IN THE CANADIAN MUSEUM OF CIVILIZATION : TRANSITIONAL WOODLAND/GRASSL AND FOOTWEAR

David Sager

3636 Denburn Place
Mississauga, Ontario
Canada, L4X 2R2

Abstract/Resume

Many specialists assign the attribution of "Plains Cree" or "Plains Ojibway" to material culture from parts of Manitoba and Saskatchewan. In fact, only a small part of this area was Grasslands. Several bands of Cree and Ojibway (Saulteaux) became permanent residents of the Grasslands borders when Reserves were established in the 19th century. They rapidly absorbed aspects of Plains material culture, a process started earlier farther west. This paper examines one such case as revealed by footwear.

Beaucoup de spécialistes attribuent aux Plains Cree ou aux Plains Ojibway des objets matériels de culture des régions du Manitoba ou de la Saskatchewan. En fait, il n'y a qu'une petite partie de cette région ait été prairie. Plusieurs bandes de Cree et d'Ojibway (Saulteaux) sont devenus habitants permanents des limites de la prairie quand les réserves ont été établies au XIXe siècle. Ils ont rapidement absorbé des aspects de la culture matérielle des prairies, un processus qu'on a commencé plus tôt plus loin à l'ouest. Cet article examine un tel cas comme il est révélé par des chaussures.

The Rose Moccasin Collection: Problems in Attribution

This paper focuses on a unique group of eight pair of moccasins from southern Saskatchewan made in the mid 1880s. They were collected by Robert Jeans Rose between 1883 and 1887. Documentation in the Canadian Museum of Civilization states that he acquired them "30 miles north of Ft. Qu'Appelle, Saskatchewan," and attributes them to the Assiniboin, perhaps on the basis of a letter from the collector's son contained in the accession documents. The Museum acquired these moccasins April 24, 1951, along with twenty-three other items (most of which are entirely consistent with a southern Saskatchewan provenance) representing both Woodland and Grasslands material. A few of the items are patently "foreign" to the rest, being from eastern Canada or the nearby eastern United States, and accessioned by the museum from the Rose family in 1965.

The bulk of the collection is of a character, and decorated in a style, highly suggestive of Woodland type. Floral beadwork is liberally in evidence on such things as navy blue stroud leggings, cloth and hide pipe bags and of course, the moccasins in question. There is one red stroud shirt decorated with wide geometrically beaded bands, of a type widely dispersed in the northern Grasslands.

What is unusual about these moccasins however, other than the seemingly inappropriate attribution of "Assiniboin," is that five out of the eight pair appear to be transitional between Woodlands and Grasslands styles in details of construction and decoration. As well there are what seem to be puzzling anomalies in both construction and in the headwork application procedure. These five pair, and to some extent two of the others, do not resemble contemporary Grasslands style moccasins examined in a recent survey undertaken by the author, of over 1,100 museum specimens spanning the period 1830 to 1940. Nor do they resemble Woodland moccasin types from slightly farther east, which were still frequently encountered among the Cree, Saulteaux and Métis bands and communities in the environmentally and culturally marginal area north of Fort Qu'Appelle (Driver, 1961:2, 5). I shall propose an explanation for these anomalous moccasins by examining their pertinent features and comparing them with known specimens from this and neighbouring areas. In the process, I hope to demonstrate how these peculiarities came to be, and why.

The region "30 miles north of Ft. Qu'Appelle" is in the southern Touchwood Hills. This region forms a part of the Central Canadian Parklands Belt, a mixed environment separating the boreal forest to the north from the grasslands to the south (Ray, 1974:28, 29) (see Figure 1).

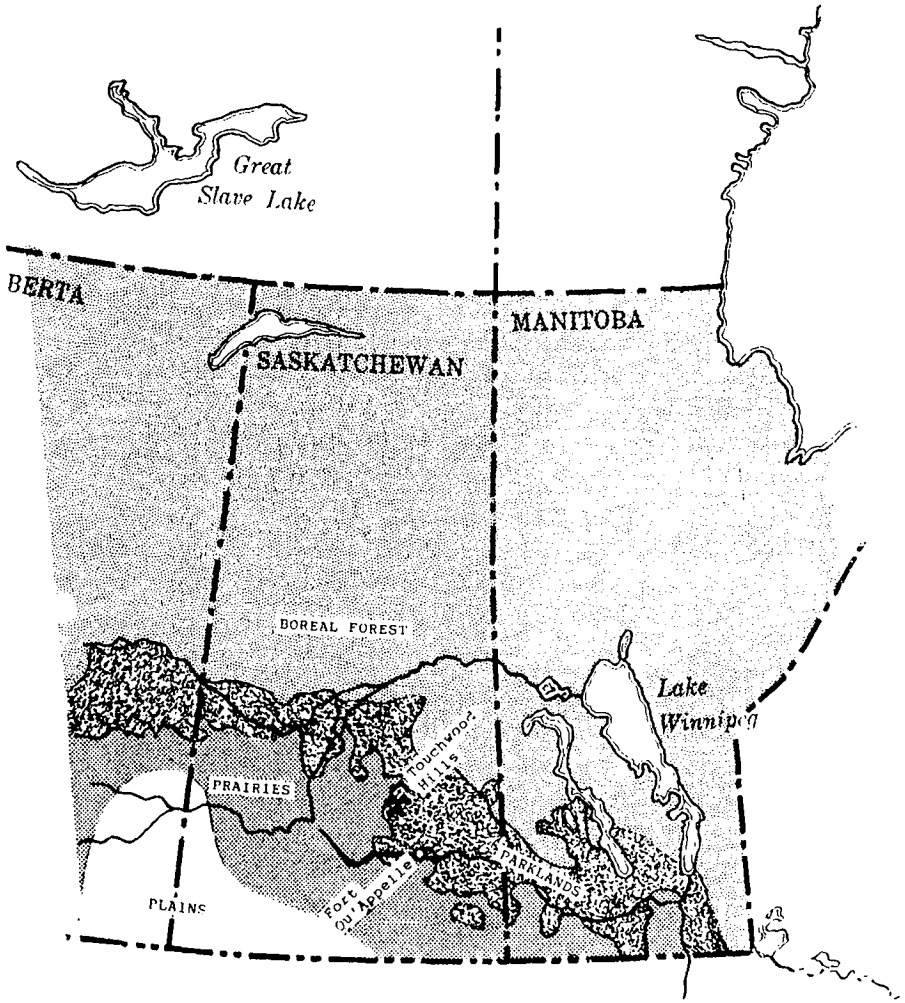

Figure 1: Natural features of regions mentioned in this paper

Notes received with the specimens, and signed by Rose's son, state, "collected by my father in 1887" and "samples of Indian bead work made by the Assiniboin and Siouxtribes."¹ Both the Assiniboin and the Sioux were represented by Bands in the general area, but their footwear types are well known and simply do not resemble Rose's material in any respect.

The Standing Buffalo Band, one of several Dakota Bands in Canada, is located six miles west of Fort Qu'Appelle itself (not 30 miles north). Numerous Dakota specimens have been accessioned by the Manitoba Museum of Man and Nature, the Canadian Museum of Civilization, the Royal Ontario Museum and the Glenbow Museum. Nothing remotely similar to the Rose specimens is to be found in these collections.

As for the Assiniboin, these people had moved west and south of the Touchwood Hills before 1856 (Denig, 1961:63, 64). There were a few incidences of Assiniboin, in small numbers, returning east to join Cree and Saulteaux Bands in the area of the Qu'Appelle River in the late 1800s. One such incident saw them present at File Hills before Treaty 4 in 1874. Shortly thereafter some of these people moved south to the area near Sintaluta (Carter, 1990:48). The File Hills Reserves are 15 to 20 miles northeast of Fort Qu'Appelle, again, not 30 miles north.

In any event, Assiniboin footwear examples as far back as 1860 are well known, both from examples in museum collections² and from the drawings of Rudolph Kurz (1937). Lowie helped to establish their typology (1909:20-23). As well, there are at least 400 pair in museum collections, over 200 of which I have examined. None resemble the Rose Collection in any respect. We must assume Rose's son was in error. His father may have visited the Assiniboin and Dakota, but not in the Touchwood Hills; he certainly did not acquire the contentious moccasins from either people.

Having determined who was not likely to have made the Rose moccasins, we may now look to more likely candidates. The most numerous people in the Saskatchewan parklands region were the Cree and the Saulteaux. The Cree were very widely represented in „Saskatchewan. Swampy Cree and remnants of the "Home Guard" Indians surrounded the northern end of Lake Winnipeg in the late 1800s (Rhodes and Todd, 1981:55; Figure 2). All the region south of Mukutawa River surrounding the Lake was occupied by the Saulteaux (Steinbring, 1981:244,245), a western extension of the Ojibway. More Saulteaux were scattered through the region both west and east of the Assiniboine River, and the nearby Parklands. Some of these latter were unquestionably Woodland Indians, following the hunting and trapping regimen for which they are well known. Others in the Parklands combined hunting and trapping with some farming (Ray, 1974:178; Denig, 1961:105), while yet others were on again, off again

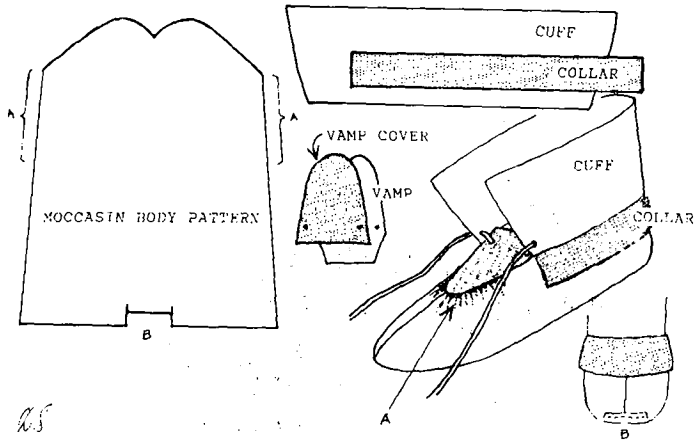

Figure 2: Centre Seam/Vamp Moccasin CMC 179

The angled line and curving notch at the top of the pattern forms the centre seam which begins slightly under the toe and terminates at the vamp. "A" is the area which will be puckered as it is sewn around the vamp front.

With the rectangular incision forming the bottom, the two sides of the base of the pattern are brought together, producing a vertical heel seam in the shape of an inverted "T". The small horizontal flange is turned up and stitched to cover the cross bar of the inverted "T" in the heel. The collar (shaded) is inserted between the moccasin body and the cuff. The cloth vamp cover is beaded, then sewn to the vamp. Silk-wrapped horse hair pipings are stitched down to cover the vamp seam.

bison hunters. The term "Plains Ojibway" is often applied to these people, though they were never as committed to the nomadic Grasslands life as were, for example, the Assiniboin and Blackfeet (Mandelbaum, 1979:8).

Plains Cree also often shared this somewhat indefinite lifestyle role, though some of their Bands, such as the Nehiopwat, spent far more time on the Plains and Prairies, following the bison herds (Mandelbaum, 1979:9-11; Dempsey, 1984:12, 26, 36, 37).

The Cree and Saulteaux Bands to be found around the Touchwood Hills by the 1880s were an interestingly mixed population of Plains Cree, Swampy Cree, Woods Cree, Saulteaux and Métis. Mixtures of clothing styles, kinship systems, religious observations and Band organization systems characterized many of their groups (Mandelbaum, 1979:11,127, 343; Carter, 1990:46). Some embraced Plains Cree or Plains Ojibway identity to a recognizable degree; indeed, most were essentially more Cree than Saulteaux or more Saulteaux than Cree. Throughout the second half



Figure 3: Photo by D. Sager (CMC VC 179)

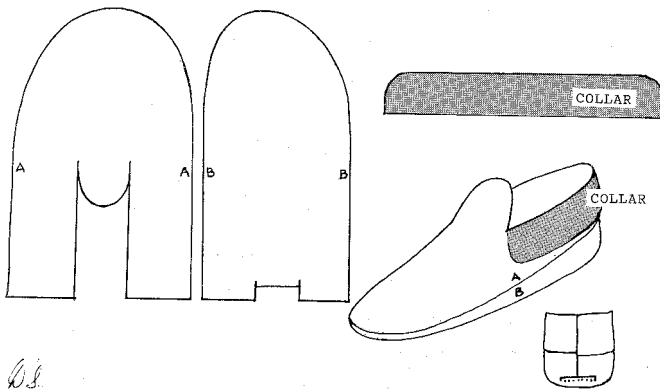

Figure 4: Dual Side Seam Moccasin (slipper form) CMC VC 159 & 161

Basic plan is identical to the Side Seam style (Figure 7), except that it is in two pieces instead of one. The two main pieces are sewn together, forming a raised perimeter seam. The top piece (A-A) contains the ankle opening and integral tongue. The rectangular incision at the base of the bottom piece (B-B) produces the cross bar on the inverted "T" shaped heel seam. The ornamental cloth collar or down-turned cuff (shaded) is simply sewn to the edge of the ankle opening. There are no tie strings.



Figure 5: Photo by D. Sager (CMC VC 159)



Figure 6: Photo by D. Sager (CMC VC 161)

of the 19th century a gradual shift to the west and southwest was evident, in a futile search for the ever-declining bison herds (Mandelbaum, 1979:11).

Relating these inconsistencies to their footwear, in the Touchwood Hills region we can expect to see the persistence of Woodland moccasins, plus an increasing acceptance of Plains moccasin types, and other Plains material, late in the 19th century.

The Rose Moccasin Collection Described

Most of the moccasins collected by Rose show significant relationships. Though there are several construction techniques present, the beaded designs and the beadwork application methods employed both suggest one person or members of one family as their makers. This is true for five of the eight pair. The other three may or may not stem from this proposed limited source. One pair in fact, VC 165, appears to have been made elsewhere, and was either purchased by Rose independently of the others, or was originally acquired by the Indians Rose dealt with, and sold to him along with the others. All are constructed of Native smoke-tanned skin, except VC 165 whose bottom piece may be Euro-Canadian leather. Most are sewn together with Euro-Canadian textile thread and the applique beading is applied in both sinew and thread.

Catalogue number VC 179 (Figures 2 and 3) is a Centre Seam/vamp3 moccasin. This is a true moccasin (Hatt, 1964:151) with a short centre seam originating just under the toe and terminating at the front of a small vamp at the instep. The vamp is in two layers, the top layer of which is black trade cloth and reaches a short distance up the tongue. The hide vamp under this extends back, forming a tongue which is cut on an angle at each side. A large, separate, upright cuff is sewn to the ankle opening, from one side of the tongue to the other. A long tie string is threaded through six holes around the upper edge of the moccasin body, plus two at the root of the tongue and one in each lower front cuff edge. A black trade cloth collar is stitched into the ankle/cuff seam and circles the ankle below this seam. A "collar" is, in this sense, a decorative strip of hide or cloth serving no other obvious purpose. Sometimes great care is taken to decorate this feature with cloth, ribbon, beads or quills. When the collar is employed where no ankle cuff is present, it serves the purpose of a downturned decorative cuff and cannot be separately distinguished.

The vamp is decorated with a stylized, four petalled floral beaded device, from the junctures of which several curving bead strands or stems protrude. Three pipings of silk wrapped horse hair cores are sewn over the vamp edge seam. This is a typical late 19th century Subarctic moccasin of

the type generally worn by Saulteaux, Cree and Métis in the wooded regions of eastern Saskatchewan and, to a lesser extent, in the eastern Grasslands as well. Very similar moccasins appear throughout the Athabaskan populations farther north.

One of the pair contains a label bearing the message, "My Own Moccasins" and "Robert Erstafieff Rose." On the reverse is printed "Form Or-5408*/Vilmington, Del., 19 ... ," and in red, "Dupont Dyestuffs" within a red oval above "Reg. US Pat. Off." These moccasins are in a child's size and apparently were the proud possession of the collector's son.

Catalogue number VC 159 (Figures 4 and 5) is a Dual Side Seam moccasin. It is made with a separate upper piece and a separate bottom piece attached around the perimeter in a seam roughly equidistant from ankle to ground. The upper is joined at the heel in a simple vertical seam. The heel seam on the lower piece is shaped like an inverted "T", a convention which produces the necessary cup shape to enclose the heel. A small semi-lunar tongue is of the integral type, which is to say it is cut into the upper moccasin body itself, not a separate piece.

At the ankle opening, a down turned red trade cloth collar or cuff is stitched in place. There is no vertical cuff. The collar is bound at the edge with dark blue cloth and trimmed with small units of beading. The forward upper moccasin surface is solidly beaded in applique stitch, a process

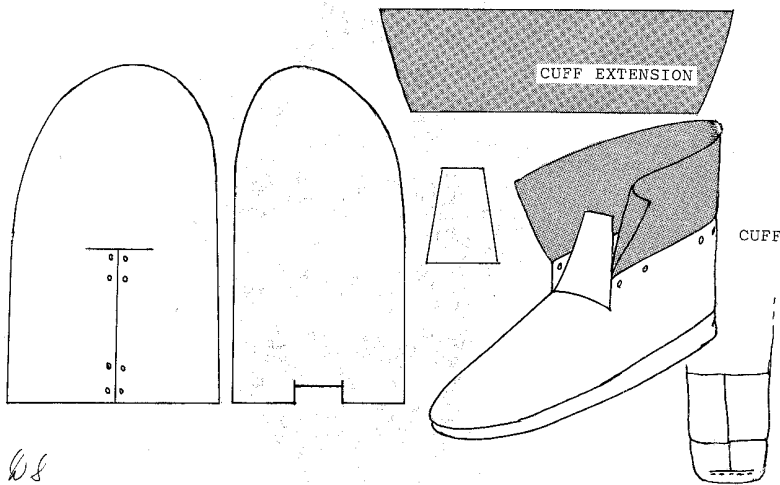

wherein a thread of beads is couched in place with a separate thread. The

Figure 7: Dual Side Seam Moccasin (CMC VC 165)

Basic plan is similar to Figure 2 except that the ankle opening is cut in such a way to incorporate a low integral cuff. The tongue is a separate piece. The shaded area is a cloth cuff extension to the integral hide one.

design consists of an asymmetrically arrayed stylized floral device with a filled-in background of white applique beading, many parts of which are oriented in whatever direction appears to have been convenient to the beadworker.

Catalogue number VC 161 (Figures 6 and 4) is also a Dual Side Seam type. It is constructed in the same manner as VC 159. The black trade cloth collar (or cuff) with red cloth binding is similarly beaded also. The tongue too is similar; a small semi-lunate, integral with the moccasin body. The perimeter of this tongue is bound with purple-blue satin. Just inside this binding is a row of lazy stitch beaded triangles which also span the base of the tongue.

Again, the upper front is solidly beaded in the applique stitch, also with a random fill-in background, light blue in this case. This example is peculiar, as are three others in the collection, in the apparently unfinished toe area. The solid beading ceases abruptly before reaching the anterior limit. As if in afterthought, a single strand of applique beading extends from around



Figure 8: Photo by D. Sager (CMC VC 165)

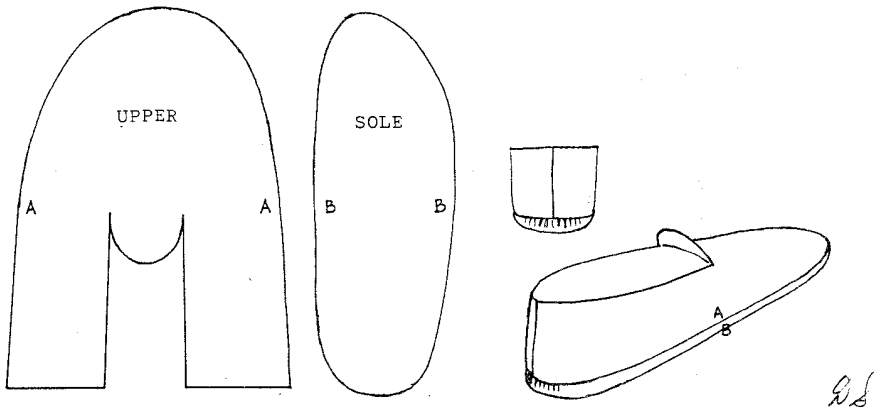

Figure 9: Separate Sole Moccasin (slipper type) CMC VC 160

Large piece at left covers entire upper surface of foot. It is sewn to sole (A to B), but oversized heel requires puckering in order to join properly. This may be intended to create the raised seam present on Dual Side Seam moccasin types (Figures 2 and 3). Tongue is integral. No tie strings.



Figure 10: Photo by D. Sager (CMC VC 160)

the perimeter of the main beaded area, thence around the tip of the toe to the other side.

Catalogue number VC 165 (Figures 7 and 8): although this too is a Dual Side Seam moccasin, it differs significantly from the other Rose specimens in several respects. In the first place this is an integral cuff design with a separate, added tongue. In other words, the top piece is cut in such a way that there is a low cuff circling the ankle opening which is an integral part of the moccasin itself. If a tongue is desired, and it usually is, it must be added as a separate piece in the opening created by the transverse cut that corresponds to the front of the cuff.

There is a further upright cloth cuff added to the top edge of the integral hide one and a red trade cloth collar is inserted in the resulting seam.

Most construction stitching in the others is with textile thread, but both thread and sinew are used here. Although I cannot be certain, because of the limited time made available to me for examination, it appears the lower piece is made of Euro-Canadian leather rather than Native tanned hide.

Unlike the slipper type Rose specimens, this one has a tie string threaded through eight holes in the cuff. A small red trade cloth flange is sewn into the tongue seam. The shape of the tongue, as visible in the

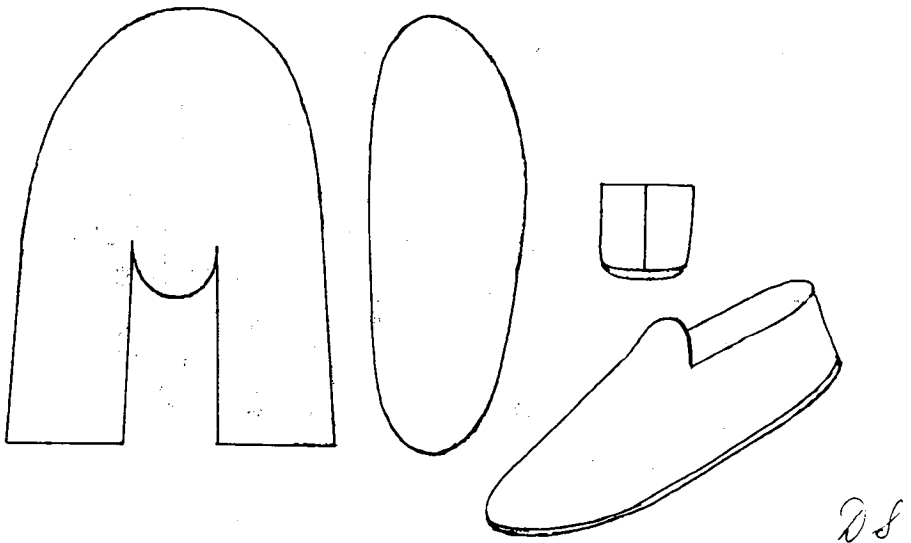

Figure 11: Separate Sole Moccasin (slipper type) CMC VC 162 and 163

Identical to Figure 4 except for conventional heel width.

sketch, the cut and stitching of the heel seam, the presence of a tie string and other details, contrast sharply with the rest of this group.

The front surface is decorated much more in the manner of long established Grasslands peoples. All beadwork is in the lazy stitch technique. One lane of lazy stitch forms a "bridge," proceeding transversely across the instep, from one side of the imprint line to the other. Another lane borders the front perimeter from one end of the bridge to the other. Ten longitudinal lazy stitch lanes fill in the intervening space. A geometric pattern of purple transverse zig-zags on a white background spans the front, and the purple border contains a row of recumbent yellow scalene triangles.

There are four pair of Separate Sole types, all showing close affinity to the Dual Side Seam specimen VC 161. Catalogue number VC 160 (Figures 9 and 10) consists of a separate top piece with integral tongue, stitched to a separate soft sole. It too has a small, semi-lunar tongue but no collar and no cuff. The ankle opening and the edge of the tongue are bound with purple tape.

This type is characterized by a straight vertical heel seam. The sole, ordinarily more or less foot shaped, is in this case quite large at the heel. Oversized soft soles occasionally appear among Grasslands groups. These ones are unusual in the fact that the heel alone is oversized, and it is puckered or pleated to produce a cuplike cavity. This process raises the sole seam noticeably at the rear, creating a superficial resemblance to the Dual Side Seam moccasin type.

The solidly beaded front is so close to that of VC 161 that one feels the same beadworker produced both. The background beadwork is light blue and again the toe tip is unbeaded, except for the single strand bordering the perimeter.

Catalogue number VC 162 (Figures 11 and 12) is a Separate Sole type, precisely like VC 160, except for the absence of the puckered, oversize heel. It too has neither cuff nor collar and the tongue and ankle opening edges are bound with reddish purple tape.

Catalogue number VC 163 (Figures 11 and 13) resembles VC 162 in all respects excepting a minor variation in the floral beaded design.

Catalogue number VC 164 (Figures 14 and 15) is a Separate Sole type similar to VC 160 in having a slightly puckered sole seam at the heel. It also has a slightly longer integral tongue than most of the Rose specimens, and an added high cuff of smoke tanned hide. There are no visible signs of a tie string. The entire top interior, including the tongue, is lined with wool cloth.

This example is solidly beaded on the front surface in a geometric design consisting of a large stepped triangle composed entirely of juxta-



Figure 12: Photo by D. Sager
CMC VC 162



Figure 12: Photo by D. Sager
CMC VC 163

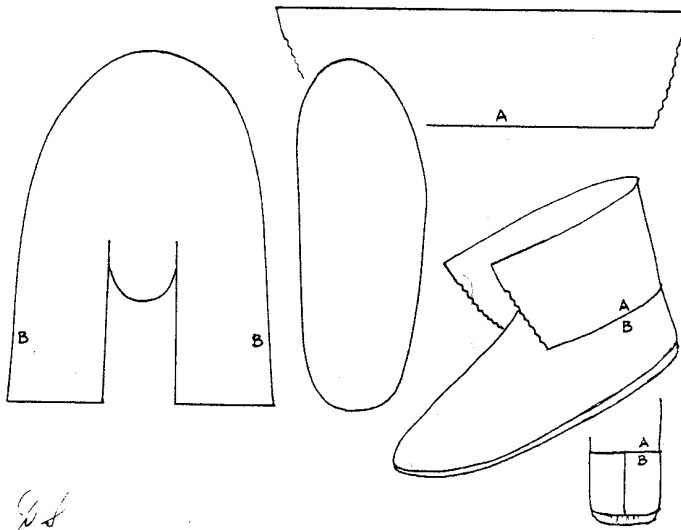

Figure 14: Separate Sole Mocassin (cuffed slipper) CMV VC 164

Identical to Figure 4 except puckering in the sole at the heel is minimal, and a cuff is sewn onto the edge of ankle opening.



Figure 15: Photo by D. Sager (CMC VC t64)

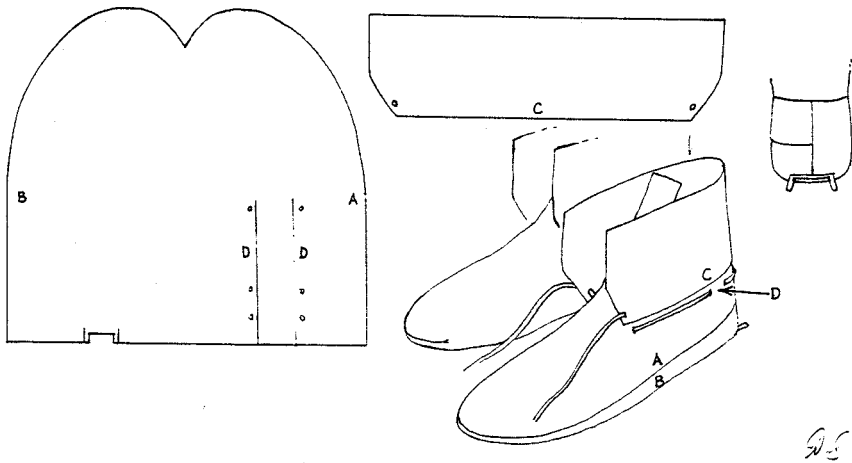

Figure 16: Side Seam Moccasin

Same basic plan as Dual Side Seam except upper and lower pieces are contiguous on inner side of foot. Outer seam is joined, A to B. Vertical heel seam is the same as in Dual Side Seam, but rectangular incision is elaborated to incorporate two small tabs which, when assembled, protrude from "T" shaped cross seam. Typically tongue is integral and quite long. A high cuff is usually present, joined to ankle seam (C to D). This moccasin type is not present in Rose collection, but was the standard northern Grasslands footwear in the second half of 19th century.

posed rectangles, executed in applique beadwork. A single lane of lazy stitch beadwork forms a border, following the outer perimeter of the moccasin top. The design appearing in this border is a continuous white zig-zag on a purple background. The same toe avoidance in the beadwork reported for other specimens in this collection is present here as well. In this case however, the otherwise unbeaded area has been filled in with lazy stitch and applique beadwork designed to compliment the actual border, apparently in an effort to minimize the somewhat ad hoc arrangement.

Probable Provenance of the Rose Moccasins

Treaties 4 and 6 saw the settlement of Cree, Saulteaux and Métis Bands in the region 33 to 45 miles north of Fort Qu'Appelle in the Touch-

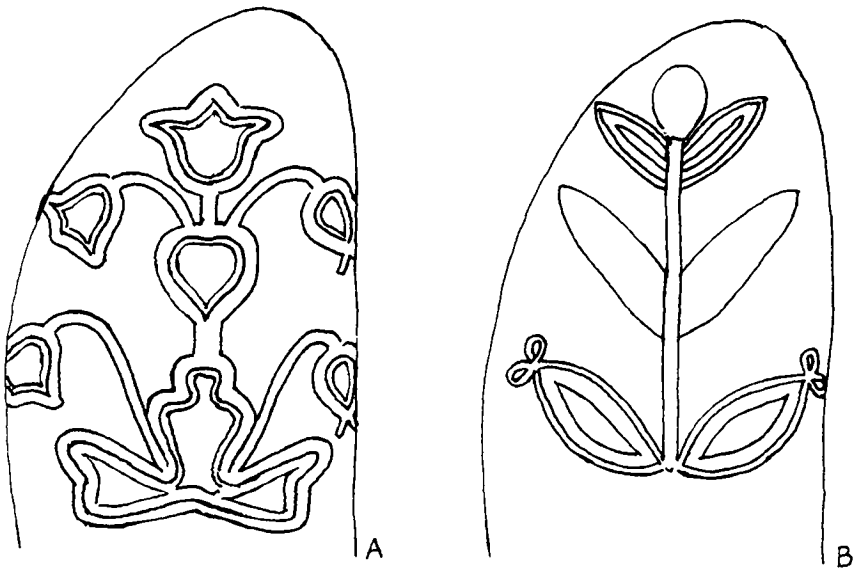

**Figure 18: Bilaterally Symmetrical Stylized Floral Layouts
From Alberta**

A. PlainsCree, Hobbema, Alberta. American Museum of Natural History, catalogue no. 50/6824. Symmetry in this case is deliberately imperfect, as elements at each side do not match those on the other. This was frequently observed.

B. Northern Assiniboin, Edmonton, Alberta area. National Museum of the American Indian, catalogue no. 14/9320

wood Hills. The southernmost of the Touchwood Hills Reserves were Gordon (IR 86), 33 miles north of Fort Qu'Appelle, and Muscowekwan (IR 85), 38 miles north. In addition, there were two Cree Reserves farther north, still in the Touchwood Hills. Gordon is listed as Ojibway and Cree, and Muscowekwan as Ojibway, in the Indian Affairs Branch (Canada) listing of Bands published in 1970. This assessment is born out in recent research conducted by Carter, who adds the fact that a Métis population was also present (1990:46, 61). Gordon's Band was settled in the Touchwood Hills a year or two after the treaty of 1874 and Muscowekwan a few years later (Carter, 1990:61).

The Cree and Saulteaux present in the Touchwood Hills area before the Reserves were established would have included Bands who were thoroughly familiar with and used Plains type moccasins, particularly the Side Seam type (Figure 16). Others would have employed the Centre Seam/Vamp type (Figure 2), in significant numbers. While a single specimen of the latter type is present in the collection, none of the former are. If these Indians were Grasslands residents they should have known the long established Side Seam type. Of course they may have. Absence of the type from Rose's collection is no guarantee that his source did not know about them. Still, their absence is noteworthy.

The Dual Side Seam moccasins in the collection stem from a minor trait found on a number of Plains Cree and Saulteaux Reserves. The Rose specimens display some peculiarities which help place them in perspective vis-à-vis footwear technology then extant in southern Saskatchewan. VC 165 is an integral cuff design. It has a fairly large trapezoidal tongue sewn into the opening created by the cut of the integral cuff. Although Plains Cree and Saulteaux Dual Side Seam and Separate Sole moccasins employed integral tongues and separate cuffs throughout much of the 19th century, the complete reversal of this procedure apparent in the case of VC 165 merely previews what was to become standard practice among these people in future years. The construction features employed are interesting as the Dual Side Seam moccasin was almost always made in the integral tongue technique, while the integral cuff method appeared quite late in the century and was usually limited to Separate Sole types.

The other two Dual Side Seam moccasins, VC 159 and VC 161, also depart from the norm. Their down turned cloth cuffs are typical of the turn-of-the-century Ojibway. Though both have the traditional integral tongue, these are in the diminutive rounded shape more commonly encountered in footwear from the Métis, Southwestern Ojibway and Santee Sioux.

There are four pair of Separate Sole moccasins in the collection. This is the most recent Native footwear form to enter the region. It seems to have



Figure 17: Photos by D. Sager



Figure 19: Saskatchewan Métis, 1870s. Bata Shoe Museum, catalogue no. P 86.0244



Figure 21: Cree or Saulteaux. Canadian Museum of Civilization, catalogue no. VX 142

had two points of origin. The variation used by more westerly-located Canadian Plains Indians is quite distinct in its method of manufacture and in decoration. The Blackfeet and Assiniboin of Alberta, Montana and North Dakota appear to have acquired the Separate Sole method from the Indians of the upper Missouri River, perhaps as early as 1860. Over the next twenty to twenty-five years it was adopted by the Sarsi, Stony, Plains Cree and western Saulteaux. Originally it was characterized by a hard rawhide sole. In fact, this was the only thing to recommend its use, as the earlier Side Seam type was far easier to make. Nonetheless, once the type was firmly implanted, Separate Sole moccasins continued in vogue even when the hard rawhide sole was replaced by one of soft-tanned moose-hide by many Canadian craftswomen (Howard, 1984:76).

There was another source for this form of footwear however, one which is all too often overlooked. The Cree and Saulteaux of Saskatchewan were familiar with one produced by their own kinsmen and the Métis at the mission schools and posts in Manitoba: at Red River, Norway House, Nelson House and elsewhere (Hail and Duncan, 1989:32, 160-62, 164). Remarkably, this version of the Separate Sole moccasin seems to have been an independent development modeled from European ladies' delicate slippers under the tutelage of Euro-Canadian nuns and teachers who had set up stitchery classes for the instruction of Native girls. They were originally richly embroidered with silk in purely European floral designs and

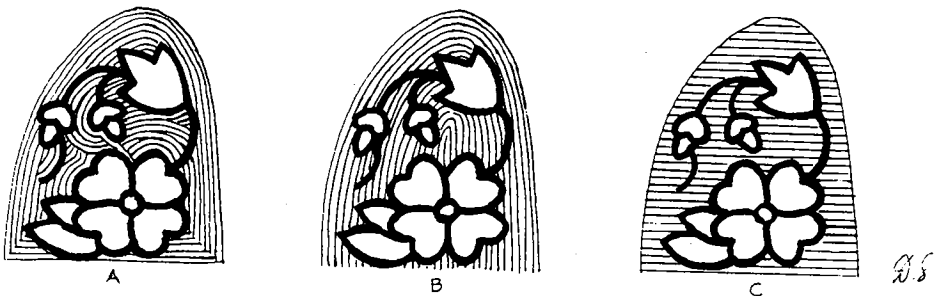

Figure 20: Background Beadwork Application Comparison

In **A**, beaded strands are randomly placed between design elements to fill in open areas.

In **B**, strands follow perimeter line of foot and fill in open areas.

In **C**, background bead strands are laid transversely across area to be covered.

B and **C** were most commonly observed in Plains floral beaded examples of the 1880s. **A** was sometimes encountered in the Saskatchewan parklands region.

formed a much needed source of income for Native communities (Figure 17). It is from European sources that the majority of western floral beadwork evolved (Barbeau, 1930:512).

Over time, the floral designs developed into various different styles, apparently of Native inspiration, a process in which the resident Métis were deeply involved (Hail and Duncan, 1989:30, 31). Also, beadwork came to be as important as silk had been for the execution of these rich designs. As the floral idiom spread into the Grasslands it changed significantly, sometimes becoming so stylized as to appear virtually unrelated to its source (Figure 18). But the basic European construction philosophy remained intact in the hands of these Woodland-based people, even though they rarely wore the finished product themselves.

Outwardly the soft soled moccasin-slipper of the Lake Winnipeg schools demonstrates very little basic difference from the hard soled versions of the High Plains, though their mutual origins seem to be separate. In detail however, they are quite different. The Rose specimens for example, are of a delicate, low profile. The opening is large, as it is in most slippers. The front surface is correspondingly small. One sees an approach to the Plains ideal in VC 164 (Figure 14) where a longer tongue and high cuffs are employed, though still no tie strings. Also present in this specimen is a large geometric beaded design not unlike, in form at least, the kind encountered on Grasslands moccasins. In any event, most of the soft soled specimens acquired by Rose from an area 30 miles north of Fort Qu'Appelle are apparently a slightly later version of the "made for sale" examples described, and probably intended to fill the same purpose.

In the Separate Sole specimens we see two examples of puckering in the posterior of the sole, more so in VC 160 than in VC 164. The whole idea of puckering any part of the moccasin, in this time period, is alien to Grasslands technology. It is however, a universal trait among Woodland Indians. I wonder if this is a deliberate procedure, carried out by erstwhile Woodland-oriented Indians, using a method known to them in order to achieve a good fit? Or is it simply an effort to use known methodology to achieve a "Plains" look in a moccasin type with which the maker is only vaguely familiar? It certainly is unusual.

The Rose slippers form part of an ongoing phenomenon, begun in eastern Manitoba and gradually spread across the west and into the Subarctic. They represented a cottage industry commodity which could be prepared anytime and sold wherever a non-Native market presented itself, such as a trading post, fort or settlement. Regional peculiarities developed. Though they remained, for the most part, a visibly Native craft in buckskin and beads, individual styles evolved within distinct Indian and Métis groups.

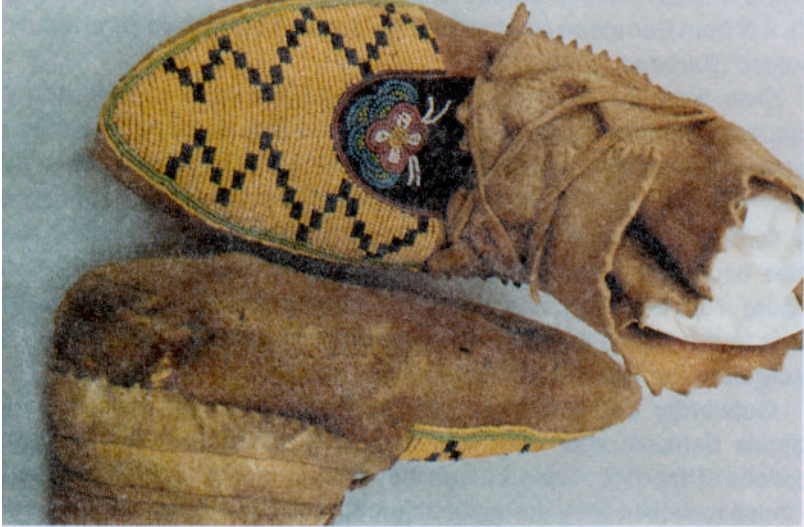

Figure 22: Saulteaux. Photo by D. Sager



Figure 23: Northeastern Grasslands, Bata Shoe Museum, P 80.1028.
Photo by D. Sager



Figure 24: Photo by D. Sager (ROM NS 42459)

Usually they are mere decorative than functional, but some groups such as the Santee Dakota and the Sioux Métis generated a conventional outdoor version incorporating some of the Manitoba features. In most cases however, the basic slipper form remained more or less intact.

The Saskatchewan Métis also created a slightly sturdier version for their own use, and actually wore them on public occasions. Some specimens made in the 1870s exist as family treasures today, as do more conventional moccasins. That they were carried about and used for special occasions is suggested for example, by a pair collected in the Batoche area by Arthur Chester, a member of the Governor General's Foot Guard, during the Rebellion.⁴ That they were sometimes made for personal use rather than just to sell, is suggested by the fact that two pair were family heirlooms of Ambrose Lepine's descendants⁵ (Figure 19). Lepine was an advisor to the Métis leader Louis Riel.

These cases are fairly exceptional. For the non-Métis Native groups, slippers were almost always made for sale. Of the many hundreds of photographs published, featuring Grasslands Indians wearing Indigenous footwear, virtually all of them wear the conventional Side Seam, Dual Side Seam, Separate Sole and occasionally, the Centre Seam/Vamp types.

The Rose moccasins fall within the former category. They are highly ornate, loose fitting slippers without tie strings to secure them to the foot and, for the most part, without vertical cuffs to protect the ankles. This being the case, the "made for sale" hypothesis looms paramount. I feel the small rounded tongue betrays Métis influence, the same influence which saw the application of small rounded tongues and slipper format in Woodland moccasin style slippers elsewhere.

The beadwork peculiarities reveal some interesting possibilities too. I have mentioned the presence of random directional background beading which is used to fill in the areas between stems, leaves and blossoms. Background beading rarely appeared in the floral beaded moccasins of the Cree until near the end of the century, if not later. Also, the use of randomly placed background beading, while it may have been used by the Cree in some of their craftwork, is usually present in work attributed to the Saukteaux or Ojibway in this period (Figure 20).

The floral design elements themselves are difficult to assign exclusively to one particular culture group or another. The borrowing of design ideas was endemic, particularly among such closely allied peoples as the Cree and Saukteaux. However, if anything, I feel the philosophy behind these floral designs leans slightly towards the Saukteaux. Both bilaterally symmetrical and asymmetrical layouts were practiced by both people, but the relatively open layouts with widely separated elements are probably mere

often encountered in Woodland Saulteaux work than in that of the Woodland Cree. It is necessary to think in terms of Woodland versus Grasslands techniques and peoples because so much of the Rose material displays Woodland influence. A nice example of Saulteaux floral embroidery, displaying strong resemblance to that on the Rose floral beaded moccasins, may be found in catalogue number 20, in Hail and Duncan's work (1989). This example is in silk rather than bead embroidery, but there is ample evidence that the former contributed a great deal to the latter. Closer still is a small silk embroidered bag, collected by Rose (VC 172), presumably from the same source as his moccasins.

In the geometrically beaded Separate Sole specimen, VC 164, an interesting beading technique is employed which also suggests Saulteaux attribution, not because it is typical of the Saulteaux of Saskatchewan or Manitoba, but because it resembles some of the Ojibway work of the Great Lakes. A solid field of parallel strands laid transversely across the surface is the usual method employed to display these big triangles or chevrons on northern Plains moccasins. In this case however, a grid of red beads is applied, then the interior areas are filled in with longitudinally applied strands of blue, pink, green and white beads. The design is most definitely Grasslands inspired but the procedure is more in keeping with Great Lakes custom. Infusions of Great Lakes crafts into southern Saskatchewan was ongoing through much of the 19th century (Mandelbaum, 1979:8).

The seemingly accidental toe-tip avoidance anomalies present in five of the Rose moccasins suggest an unfamiliarity with the solid beadwork technique, at least as it applies to moccasins. It isn't the difficulty of applying floral beaded designs that caused these anomalies; we can see that the beadworker was an expert. I suspect it was the solidly beaded backgrounds that seem to have baffled her. Though the group that produced these moccasins may have been accustomed to applying solidly beaded backgrounds, it appears this knowledge didn't extend to moccasins.

I suggest some experimentation was involved in both the construction techniques employed, and in the beadwork with which it was decorated. That this process of experimentation and adaptation resulted in a more recognizable and typical Grasslands moccasin is apparent in VC 159, where the toe-tip avoidance is finally eliminated. I do not suggest that VC 159 is necessarily a chronologically later development. Indeed, it may have been made by another member of the family, or simply another Band member. In fact, there are some noticeable differences in the beadwork technique. The design is a little closer to Grasslands norm for 1883; there are no overlapping elements, no attempt at the perspective present in other

Rose specimens. Other similarities however, outweigh these differences. Even the treatment of the cuffs is clearly related to VC 161 for example.

That the process resulted in fully recognizable Grasslands moccasins by the end of the century is amply demonstrated by the well documented Saulteaux specimens collected for the Field Museum by Stephen Simms in 1903 (Vanstone, 1983:10), and for the American Museum of Natural History by William Jones in the same year.⁶

Woodlands / Grasslands Transitional Footwear

The desire of eastern Grasslands and Parklands Indians to emulate the heavily beaded Plains moccasins was manifested in different ways. In the collections of the Museum of Civilization is a Centre Seam/Vamp moccasin (Figure 21) over the front of which is sewn the cut-off forward section of a solidly beaded Plains moccasin. The original floral textile and quillwork decorated vamp is still partially visible at the instep.

From the Provincial Museum of Alberta we have another example of altering a Centre Seam/Vamp moccasin to resemble a Plains one (Figure 22). In this case a geometric design in applique beadwork has been applied to the surface, from instep to toe, but carefully avoids the original beaded vamp, which then forms part of the overall design. In this instance the geometric beadwork was done after the moccasin was assembled, a most difficult task.

Both of these examples demonstrate a desire on the part of Woodland moccasin makers to emulate Plains ideals. Our Rose specimens seem to share some of this inspiration in that they illustrate early attempts to apply beaded designs incorporating solidly filled-in backgrounds, but in their case floral designs are adhered to for the most part, rather than geometric ones.

A related phenomenon appears on a pair of Separate Sole moccasins in the collections of the Bata Shoe Museum in Toronto (Figure 23). There is no solid provenance for these, but they are clearly made by Indians quite familiar with Plains footwear. These are hard soled moccasins with soles cut from a rawhide parfleche bag. Of particular interest is the asymmetrical floral beaded design on their front surface. This work is a fine example, in beadwork, of a popular silk embroidery theme encountered on Cree and Métis slippers from the area near northern Lake Winnipeg around 1890 (Hail and Duncan, 1989:164). Notice no background fill-in beading is attempted. Like the Rose Dual Side Seam specimens, here is typically Woodland beadwork applied to a Grasslands moccasin, a situation not unlike that of the Rose specimens, but dealt with in a different way.

Summation

The floral beadwork on the Rose moccasins does not present the unique qualities which might justify a firm attribution of Woods or Swampy Cree, Saulteaux or Métis. I do feel there is more of Ojibway than Cree character in the open, unencumbered layouts which appear on four out of the five floral beaded examples. To this one could add the Great Lakes technique employed in the geometric design on VC 164. These peculiarities both suggest the Saulteaux, a western extension of the Ojibway. This data however, is not sufficiently conclusive by itself. It was commonplace for Cree and Saulteaux to share one another's design element inventory; as well, the Métis not only participated in this milieu, but initiated a lot of it themselves.

It happens though, that these moccasins were acquired "30 miles north of Ft. Qu'Appelle," the precise location of two Reserves populated by a majority of Saulteaux. For the most part, it seems every effort was made by the craftswomen involved to produce slippers, probably specifically for sale to non-Native visitors to the area. These are not moccasins with cuffs and tie strings, suitable for walking, working or dancing under normal frontier conditions. They are delicate slippers. Where their general appearance is concerned, they are apparently derived from the trade slippers developed in the Lake Winnipeg and Red River schools, although Grasslands influence is also present.

Construction stitching is generally in textile thread rather than sinew, which was the preferred sewing medium in the 1880s among all northern Grasslands groups. That the maker or makers were familiar with Woodland techniques also seems undeniable. The puckered heels on two of the specimens otherwise resembling Grasslands types strongly suggest this. At the same time, evidence of Grasslands influence is manifest in the presence of the Dual Side Seam construction technique, and in the application of solid beadwork, a process virtually unheard of in Canadian Woodland moccasin technologies before this time.

Both the Cree and various Métis groups could have been involved with this complex. They were also present. In the case of the latter, this point is almost moot. The evidence suggests mixed heritage members formed a significant percentage of the western Saulteaux group (Howard, 1961:171). Much the same could be said of the Cree from the eastern Parklands region, even its southern edge, which incorporates the Touchwood Hills.

Insofar as the Plains Cree are concerned, those who were indisputably Plains oriented, they simply did not produce floral beadwork in the Woodland idiom until a generation later. Their floral beaded Plains type mocca-

sins, in addition to being rare before the end of the century, were executed in flat, symmetrical layouts, even more stylized than the Rose specimens (Figure 24). As far as the Assiniboin are concerned, there is nothing present in the moccasin collection to suggest their involvement, with the exception of VC 165. Like the western Plains Cree, when the Assiniboin did produce floral beadwork, it's character was decidedly not in the Manitoba style.

I suggest this footwear was made by one or more Saulteaux or Saulteaux/Métis craftworkers from the Gordon or Muscowekwan Reserves. Furthermore, I suggest they represent one example of a marginal group's reaction to the increasing popularity of Plains style garments which was then underway, and that a local interpretation of the old Manitoba slipper was utilized for this purpose, even if only for purposes of sale.

That it came so late in history is not unusual. Well documented Plains Cree moccasins, solidly beaded in a recognizably "Plains" tradition, are fairly scarce until the 1890s. Saulteaux, Bungi or Plains Ojibway specimens of this type are scarcer still.

Notes

1. This paper stems from research in the years 1991 through 1994, and was greatly aided by a grant from the Canada Council.

I gratefully acknowledge Margot Reid and the staff of the Canadian Museum of Civilization for their patient perseverance on my behalf in examinations of the Rose and other material. As well, considerable assistance from Patricia McCormack and the Ethnology Department of the Provincial Museum of Alberta was inestimable.

2. In museum catalogue documentation, these notes are associated with Iroquois or Maritimes material and thus totally inappropriate. The notes were clearly intended to apply to other parts of the Rose collection, but even in that context do not seem to be correct. Catalogue numbers III-I-1379 (VX 269) and 111-1-1378 (VX 268).
3. Many of the moccasin types encountered do not have widely understood typological descriptions. Hatt (1916) produced an exhaustive analysis of many types, but his terms are extremely ponderous and not widely employed. Hatt's approach was substantially updated and broadened by Webber (Bata Shoe Museum, 1989). This paper employs terminology used in the field wherever consensus seems to reign, and suggests a few new terms where they seem appropriate. There are no broadly accepted terms used to describe the Centre Seam/Vamp, Full Vamp and Dual Side Seam styles, but rather many

terms, often contradictory. The figures employed in the text should make these terms amply clear.

4. Specimens held by the Canadian Museum of Civilization in Ottawa, moccasins from Batoche area, catalogue number VZ 18.
5. Specimens held by the Bata Shoe Museum, from the family of Ambrose Dytime Lepine, 1870s, catalogue numbers P86.0243, P86.0244.
6. Specimens held by the American Museum of Natural History, collected at Turtle Mountain, North Dakota, catalogue numbers 50•4640, 50/4641.

References

Barbeau, Marius

- 1930 The Origin of Floral and Other Designs Among the Canadian and Neighboring Indians. Proceedings of the Twenty-Third International Congress of Americanists, New York.

Canada: Department of Indian Affairs and Northern Development

- 1970 *Linguistic and Cultural Affiliations of Canadian Bands*. Ottawa.

Carter, Sarah

- 1990 *Lost Harvests*. Montreal: McGill-Queens University Press.

Dempsey, Hugh

- 1984 *Big Bear*. Vancouver: Douglas and McIntyre.

Denig, Edwin Thompson

- 1961 *Five Indian Tribes of the Upper Missouri: Sioux, Arickaras, Assiniboines, Crees, Crows*. Edited by John C. Ewers. Norman: University of Oklahoma Press.

Driver, Harold E.

- 1961 *Indians of North America*. Chicago: University of Chicago Press.

Hatt, Gudmund

- 1916 Moccasins and Their Relation to Arctic Footwear. *American Anthropological Association Memoirs* 3.

Hail, B.A. and K.C. Duncan

- 1989 *Out of the North*. Bristol, Rhode Island: Haffenreffer Museum of Anthropology, Brown University.

Hewitt, J.N.B. (Editor)

- 1937 Journal of Rudolph Friederich Kury: An Account of his Experiences Among Fur Traders and American Indians on the Mississippi and the Upper Missouri Rivers During the Years 1846 to 1852. *Bureau of American Ethnology Bulletin* 115.

Howard, James H.

- 1984 *The Canadian Sioux*. Lincoln: University of Nebraska Press.
- 1961 The Identity and Demography of the Plains Ojibwa. *Plains Anthropologist* 6(3).

Lowie, Robert H.

- 1909 The Assiniboine. *Anthropological Papers of the American Museum of Natural History* IV(1).

Mandelbaum, David G.

- 1978 *The Plains Cree: An Ethnographic, Historical and Comparative Study*. Regina: Canadian Plains Research Center.

Ray, Arthur J.

- 1974 *Indians in the Fur Trade: Their Role as Trappers, Hunters, and Middlemen in the Lands Southwest of Hudson Bay. 1660-1870*. Toronto: University of Toronto.

Rhodes, Richard A. and Evelyn M. Todd

- 1981 Subarctic Algonquian Languages, pp. 52-66, in June Helm (Editor): *Handbook of North American Indians* 6. Washington, D.C.: Smithsonian Institution.

Steinbring, Jack H.

- 1981 Saulteaux of Lake Winnipeg, pp. 244-255, in June Helm (Editor): *Handbook of North American Indians* 6. Washington, D.C.: Smithsonian Institution.

Vanstone, J.W.

- 1983 The Simms Collection of Plains Cree Material Culture From Southeastern Saskatchewan. *Fieldiana Anthropology* 6.

List of Figures

- Figure 1: Natural features of regions mentioned in this paper as they appeared in the 19th century. Source: David Sager, based partially on Ray 74:28 and Driver 61 :map 5.

- Figure 2: Centre Seam/Vamp Moccasin. Canadian Museum of Civilization, catalogue no. CMC VC 179. Drawing by David Sager.
- Figure 3: Centre Seam/Vamp Moccasin. Canadian Museum of Civilization, catalogue no. CMC VC 179, negative no. K94-1530. Photo by David Sager.
- Figure 4: Dual Side Seam Moccasin (slipper form). Canadian Museum of Civilization, catalogue no. CMC VC 159 and CMC VC 161. Drawing by David Sager.
- Figure 5: Dual Side Seam Moccasin (slipper form). Canadian Museum of Civilization, catalogue no. CMC VC 159, negative no. K94-1527. Photo by David Sager.
- Figure 6: Dual Side Seam Moccasin (slipper form). Canadian Museum of Civilization, catalogue no. CMC VC 161; negative no. K94-1529, Photo by David Sager.
- Figure 7: Dual Side Seam Moccasin. Canadian Museum of Civilization, catalogue no. CMC VC 165. Drawing by David Sager.
- Figure 8: Dual Side Seam Moccasin. Canadian Museum of Civilization, catalogue no. CMC VC 165; negative no. K94-1534. Photo by David Sager.
- Figure 9: Separate Sole Moccasin (slipper type). Canadian Museum of Civilization catalogue no. CMC VC 160. Drawing by David Sager.
- Figure 10: Separate Sole Moccasin (slipper type). Canadian Museum of Civilization catalogue no. CMC VC 160; negative no. K94-1528. Photo by David Sager.
- Figure 11: Separate Sole Moccasin (slipper type). Canadian Museum of Civilization catalogue no. CMC VC 162 and CMC VC 163. Drawing by David Sager.
- Figure 12: Separate Sole Moccasin (slipper type). Canadian Museum of Civilization catalogueno. CMC VC 162; negative no. K94-1532. Photo by David Sager.
- Figure 13: Separate Sole Moccasin (slipper type). Canadian Museum of Civilization catalogue no. CMC VC 163; negative no. K94-1532. Photo by David Sager.
- Figure 14: Separate Sole Moccasin (cuffed slipper). Canadian Museum of Civilization catalogue no. CMC VC 164. Drawing by David Sager.
- Figure 15: Separate Sole Moccasin (cuffed slipper). Canadian Museum of Civilization catalogue no. CMC VC 164; negative no. K94-1533. Photo by David Sager.

- Figure 16: Side Seam Moccasin. Canadian Museum of Civilization, catalogue no. CMC VC 164. Drawing by David Sager.
- Figure 17: Separate Sole Moccasin. Royal Ontario Museum, catalogue nos. ROM 972.300.6, ROM HK559. Photos by David Sager.
- Figure 18: Bilaterally Symmetrical Stylized Floral Layouts from Alberta. A. American Museum of Natural History, catalogue no. 5016824. B. National Museum of the American Indian, catalogue no. 14/9320. Drawings by David Sager.
- Figure 19 Saskatchewan Métis. Bata Shoe Museum, catalogue no. P86.0244. Photo by David Sager.
- Figure 20: Background Beadwork Application Comparison. Drawing by David Sager.
- Figure 21: Cree or Saulteaux. Canadian Museum of Civilization, catalogue no. CMC VX 142; negative no. K94-1531. Photo by David Sager.
- Figure 22: Saulteaux. Ethnology Program, Provincial Museum of Alberta, Edmonton, Alberta, catalogue no. PMA H64.6.9. Photo by David Sager.
- Figure 23: Northeastern Grasslands. Bata Shoe Museum, catalogue no. P80.1028. Photo by David Sager.
- Figure 24: Royal Ontario Museum, catalogue no. ROM NS42459. Photo by David Sager.